

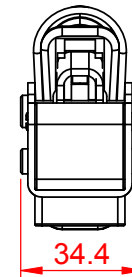

Structured Cable Products™

Quality Installations Deserve Quality Products

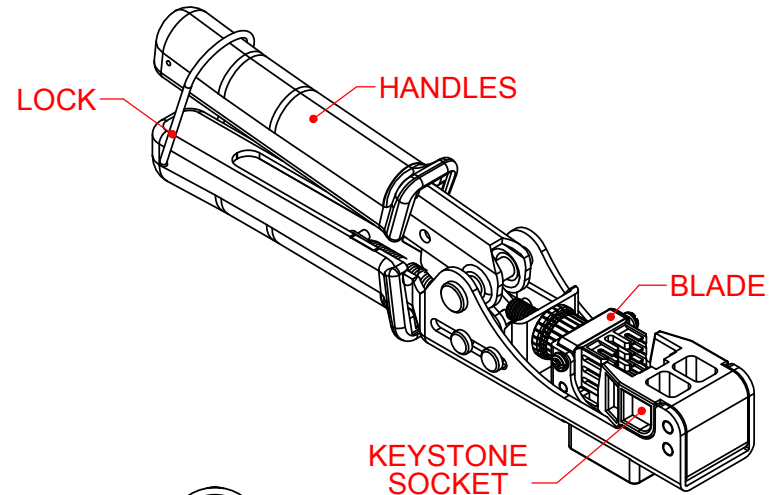
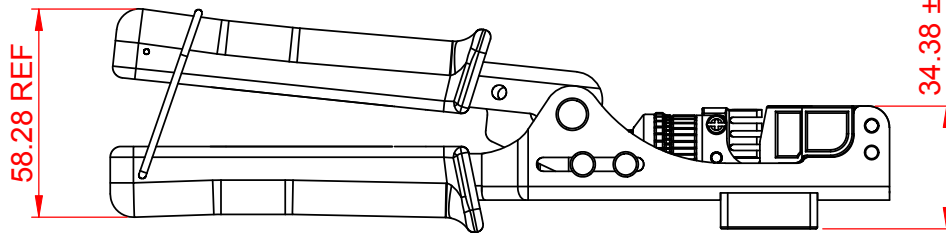
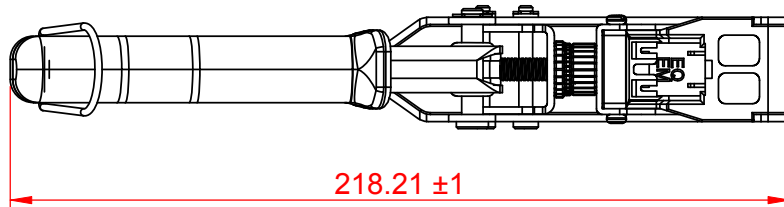

MATERIAL

MAIN BODY : CARBON STEEL.
 REPLACEABLE BLADE : ALLOY STEEL.
 FINISHED: BLACK OXIDE FINISHED.
 KEYSTONE SOCKET : PC+ABS HIGH-IMPACT UL94V-0 THERMOPLASTIC.
 HANDLES : PVC.
 WEIGHT : 380g±20g.
 SUITABLE MODEL : EM SERIES / EQ SERIES.

PHYSICAL CHARACTERISTICS

REPLACEABLE BLADE : 2000 TERMINATION CYCLES.
 CONTACT COMPATIBILITY : ACCOMMODATES 22 TO 24 AWG SOLID.
 STORAGE TEMPERATURE RANGE : -15 °C TO 50 °C.
 HUMIDITY : 10%~90%RH.



56Y4
E145249



Scale		1:2		All Copy Rights Reserved		
3rd Angle Projection				Title		
Unit		mm				
Date		2015/8/26		820		
Tolerance						
~20	~50	~150	150~	ANGLE	Drawn by Ted	Checked by
±0.2	±0.4	±0.5	±1.5	±2°		